

GS 450h

Gasoline-Electric

Hybrid Synergy Drive

***HYBRID VEHICLE
DISMANTLING
MANUAL***



Foreword

This guide was developed to educate and assist dismantlers in the safe handling of Lexus GS450h gasoline-electric hybrid vehicles. GS450h dismantling procedures are similar to other non-hybrid Lexus vehicles with the exception of the high voltage electrical system. It is important to recognize and understand the high voltage electrical system features and specifications of the Lexus GS450h, as they may not be familiar to dismantlers.

High voltage electricity powers the A/C compressor, electric motor, generator, and inverter/converter. All other conventional automotive electrical devices such as the head lights, radio, and gauges are powered from a separate 12 Volt auxiliary battery. Numerous safeguards have been designed into the GS450h to help ensure the high voltage, approximately 288 Volt, Nickel Metal Hydride (NiMH) Hybrid Vehicle (HV) battery pack is kept safe and secure in an accident.

The NiMH HV battery pack contains sealed batteries that are similar to rechargeable batteries used in some battery operated power tools and other consumer products. The electrolyte is absorbed in the cell plates and will not normally leak out even if the battery is cracked. In the unlikely event the electrolyte does leak, it can be easily neutralized with a dilute boric acid solution or vinegar.

High voltage cables, identifiable by orange insulation and connectors, are isolated from the metal chassis of the vehicle.

Additional topics contained in the guide include:

- Lexus GS450h identification.
- Major hybrid component locations and descriptions.

By following the information in this guide, dismantlers will be able to handle GS450h hybrid-electric vehicles as safely as the dismantling of a conventional gasoline engine automobile.

© 2012 Toyota Motor Corporation

All rights reserved. This book may not be reproduced or copied, in whole or in part, without the written permission of Toyota Motor Corporation.

Table of Contents

<u>About the GS450h hybrid</u>	<u>1</u>
<u>GS450h Identification</u>	<u>2</u>
<u>GS450h Identification (Continued)</u>	<u>3</u>
<u>GS450h Identification (Continued)</u>	<u>4</u>
<u>GS450h Identification (Continued)</u>	<u>5</u>
<u>Hybrid Component Locations & Descriptions</u>	<u>6</u>
<u>Hybrid Component Locations & Descriptions (Continued)</u>	<u>7</u>
<u>Specifications</u>	<u>7</u>
<u>Hybrid Component Locations & Descriptions (Continued)</u>	<u>8</u>
<u>Lexus Hybrid Drive Operation</u>	<u>8</u>
<u>Vehicle Operation</u>	<u>8</u>
<u>Hybrid Vehicle (HV) Battery Pack and Auxiliary Battery</u>	<u>9</u>
<u>HV Battery Pack</u>	<u>9</u>
<u>Components Powered by the HV Battery Pack</u>	<u>9</u>
<u>Hybrid Vehicle (HV) Battery Pack and Auxiliary Battery (Continued)</u>	<u>10</u>
<u>HV Battery Pack Recycling</u>	<u>10</u>
<u>Auxiliary Battery</u>	<u>10</u>
<u>High Voltage Safety</u>	<u>11</u>
<u>High Voltage Safety System</u>	<u>11</u>
<u>High Voltage Safety (Continued)</u>	<u>12</u>
<u>Service Plug Grip</u>	<u>12</u>
<u>Precaution to be observed when dismantling the vehicle</u>	<u>13</u>
<u>Necessary Items</u>	<u>13</u>
<u>Spills</u>	<u>14</u>
<u>Dismantling the vehicle</u>	<u>15</u>
<u>Removal of HV battery</u>	<u>18</u>
<u>HV Battery Caution Label</u>	<u>29</u>

About the GS450h hybrid

The GS450h joins the LS600h L, RX450h, HS250h and CT200h as a hybrid model for Lexus. Lexus Hybrid Drive means that the vehicle contains a gasoline engine and an electric motor for power. The two hybrid power sources are stored on board the vehicle:

1. Gasoline stored in the fuel tank for the gasoline engine.
2. Electricity stored in a high voltage Hybrid Vehicle (HV) battery pack for the electric motor.

The result of combining these two power sources is improved fuel economy and reduced emissions. The gasoline engine also powers an electric generator to recharge the battery pack; unlike a pure all electric vehicle, the GS450h never needs to be recharged from an external electric power source.

Depending on the driving conditions one or both sources are used to power the vehicle. The following illustration demonstrates how the GS450h operates in various driving modes.

- ❶ During light acceleration at low speeds, the vehicle is powered by the electric motor. The gasoline engine is shut off.
- ❷ During normal driving, the vehicle is powered mainly by the gasoline engine. The gasoline engine also powers the generator to recharge the battery pack and to drive the motor.
- ❸ During full acceleration, such as climbing a hill, both the gasoline engine and the electric motor power the vehicle.
- ❹ During deceleration, such as when braking, the vehicle regenerates the kinetic energy from the rear wheels to produce electricity that recharges the battery pack.
- ❺ While the vehicle is stopped, the gasoline engine and electric motor are off, however the vehicle remains on and operational.

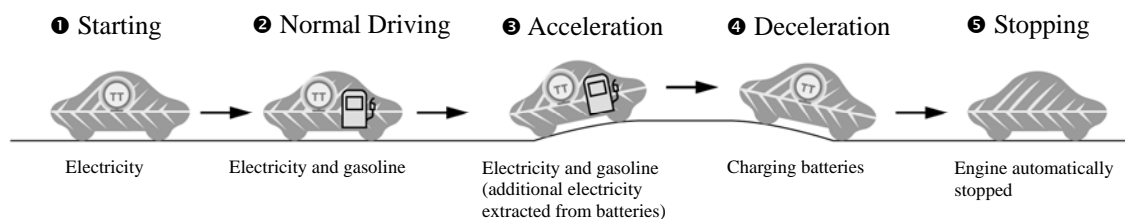

GS450h Identification

In appearance, the 2012 model year GS450h is a nearly identical to the conventional, non-hybrid Lexus GS350/250. The GS450h is a 4-door sedan. Exterior, interior, and engine compartment illustrations are provided to assist in identification.

The alphanumeric 17 character Vehicle Identification Number (VIN) is provided in the front windshield cowl, engine compartment, and on the left side B pillar.

Example VIN: JTHBS1BL0D5000101
JTHBS5BL005000101

A GS450h is identified by the first 8 alphanumeric characters **JTHBS1BL** or **JTHBS5BL**.

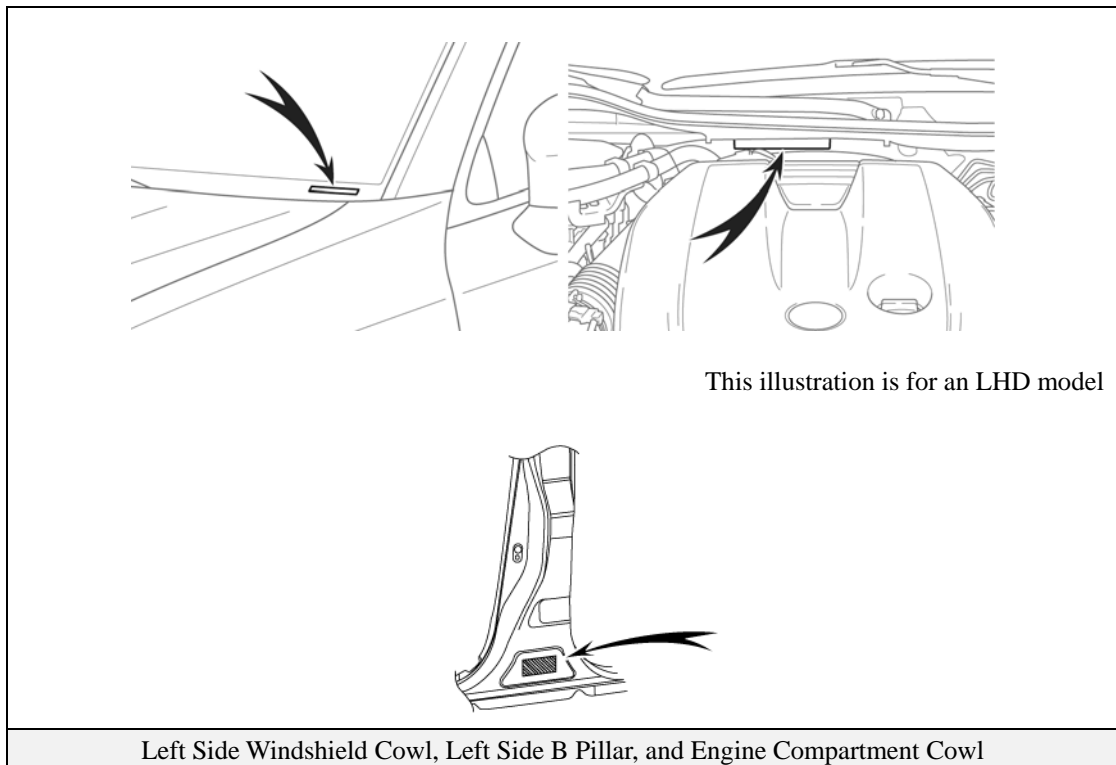

GS450h Identification (Continued)

Exterior

- ❶ **GS450h** logos on the trunk.
- ❷ **HYBRID** logos on the rocker moldings.
- ❸ Gasoline fuel filler door located on left side rear quarter panel.
- ❹ Lexus logo on the radiator grille.



Exterior Left Side View



Exterior Front and Rear View

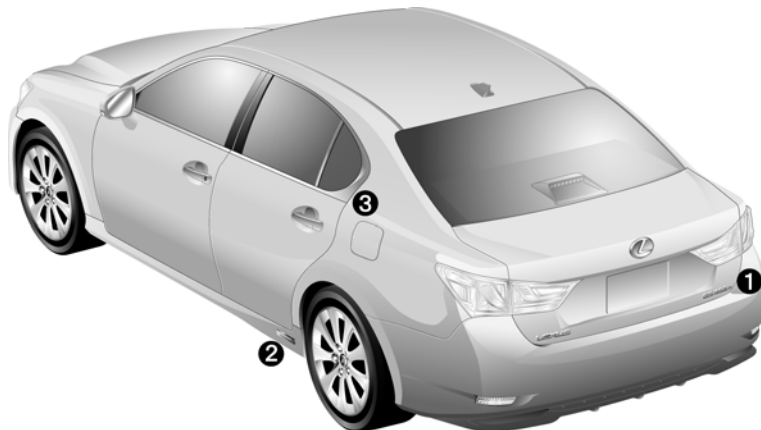

Exterior Rear and Left Side View

GS450h Identification (Continued)

Interior

- ⑤ The instrument cluster (hybrid system indicator, **READY** indicator and warning lights) located in the dash behind the steering wheel, is different than the one on the conventional, non-hybrid GS350/250.
- ⑥ A switchable gauge in the instrument cluster showing either a hybrid system indicator or a tachometer depending on driving mode.

Notice:

If the vehicle is shut off, the instrument cluster gauges will be “blacked out”, not illuminated.

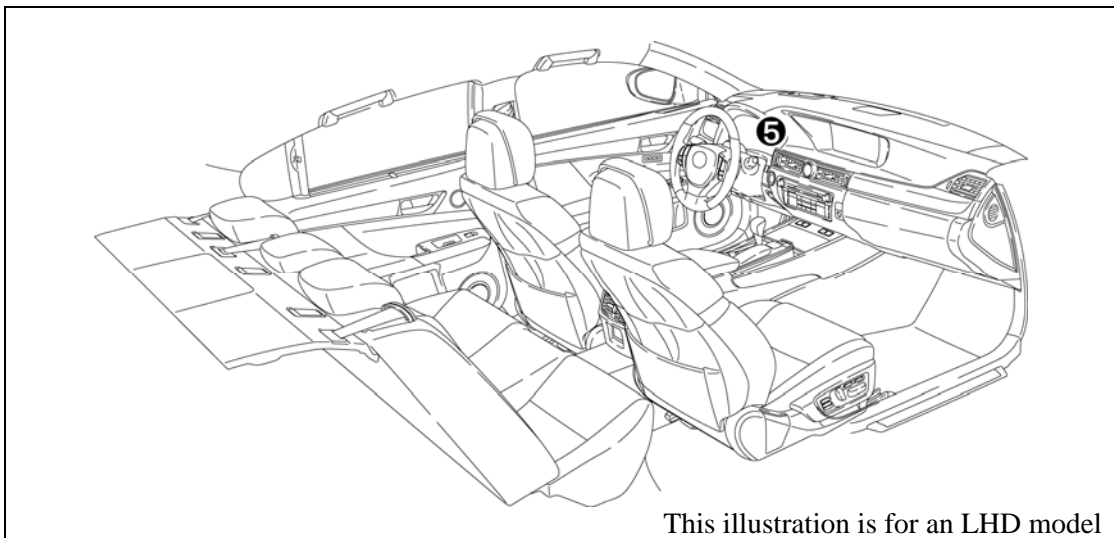

Interior View

⑤ ⑥

Hybrid System Indicator

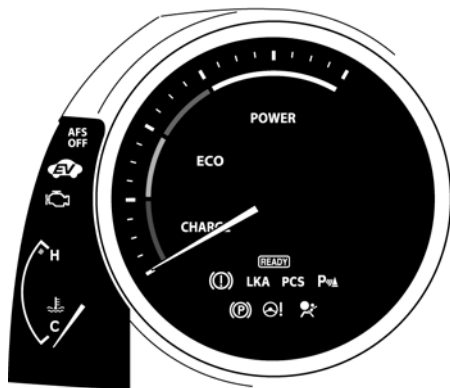

Tachometer

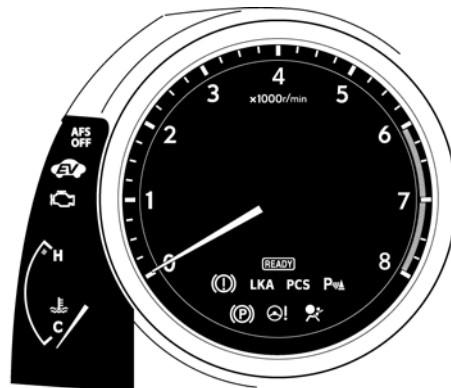

Instrument Cluster View

GS450h Identification (Continued)

Engine Compartment

- ⑦ 3.5-liter aluminum alloy gasoline engine.
- ⑧ Logo on the plastic engine cover.
- ⑨ Orange colored high voltage power cables.

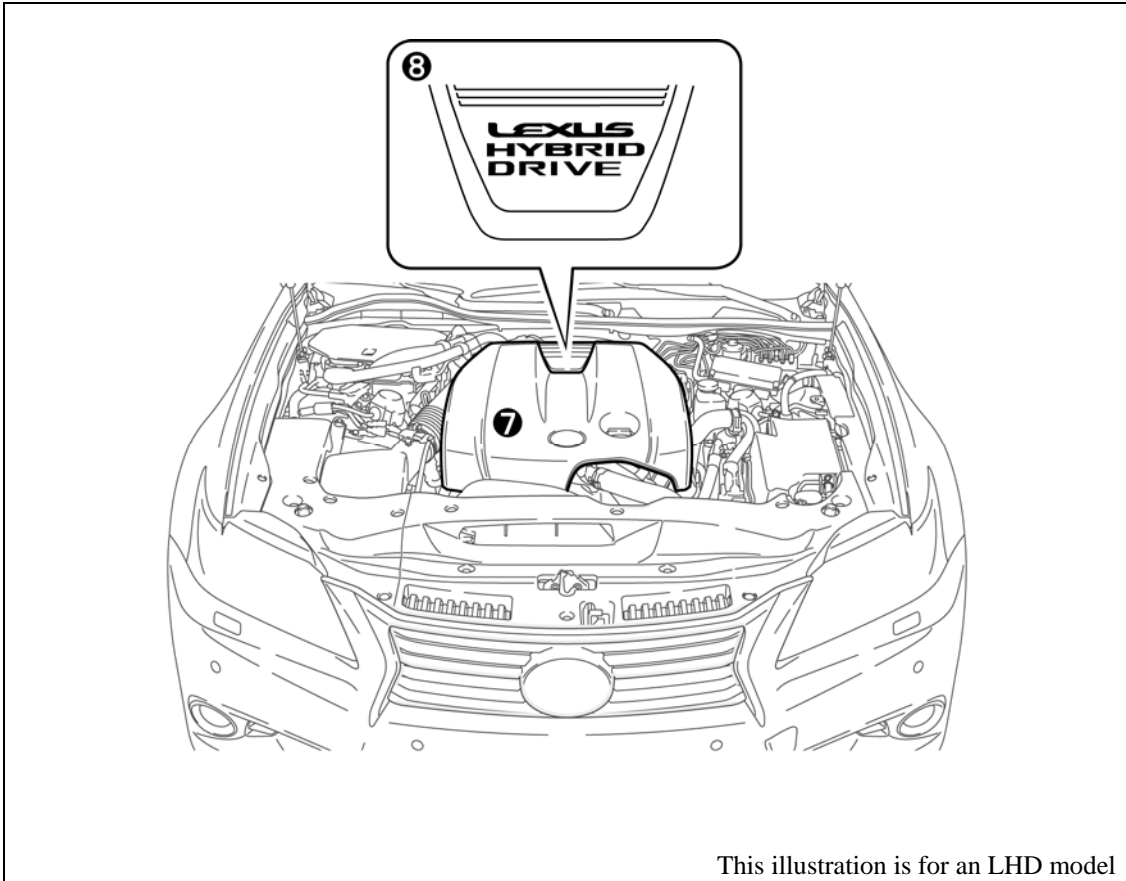

Engine Compartment View

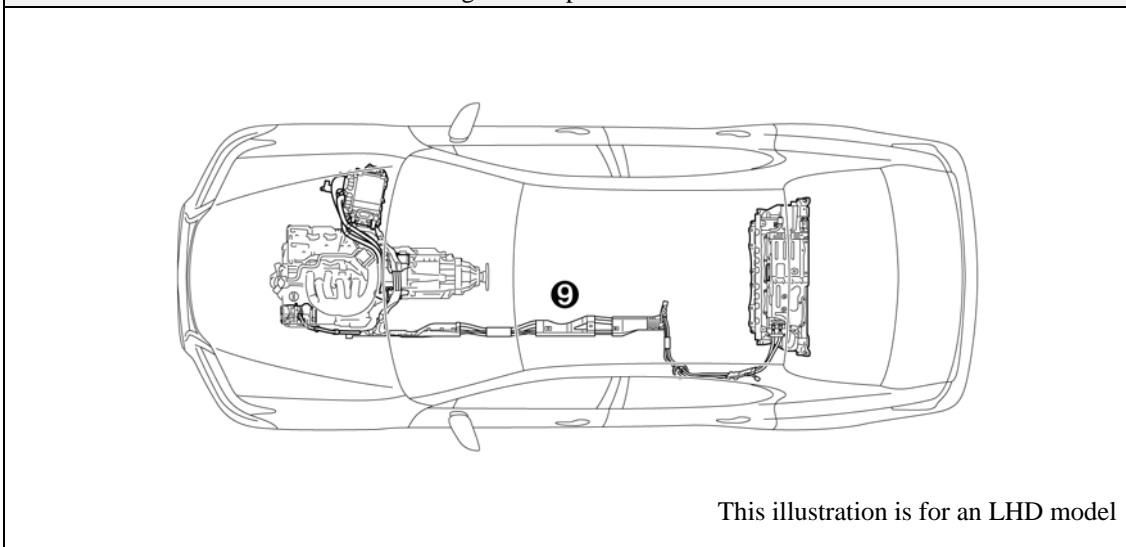

Power Cables

Hybrid Component Locations & Descriptions

Component	Location	Description
12 Volt Auxiliary Battery ❶	Left Side of Trunk	A lead-acid battery that supplies power to the low voltage devices.
Hybrid Vehicle (HV) Battery Pack ❷	Trunk Area, Mounted behind Rear Seat	288 Volt Nickel Metal Hydride (NiMH) battery pack consisting of 40 low voltage (7.2 Volt) modules connected in series.
Power Cables ❸	Undercarriage and Engine Compartment	Orange colored power cables carry high voltage Direct Current (DC) between the HV battery pack, inverter/converter, and A/C compressor. These cables also carry 3-phase Alternating Current (AC) between the inverter/converter, electric motor, and generator.
Inverter/Converter ❹	Engine Compartment	Boosts and inverts the high voltage electricity from the HV battery pack to 3-phase AC electricity that drives the electric motors. The inverter/converter also converts AC electricity from the electric generator and electric motor (regenerative braking) to DC that recharges the HV battery pack.
Gasoline Engine ❺	Engine Compartment	Provides two functions: 1) Powers vehicle. 2) Powers generator to recharge the HV battery pack. The engine is started and stopped under control of the vehicle computer.
Electric Motor ❻	Transmission	3-phase high voltage AC permanent magnet electric motor contained in the transmission and drives the rear wheels through the propeller shaft.
Electric Generator ❼	Transmission	3-phase high voltage AC generator that is contained in the transmission and recharges the HV battery pack.
A/C Compressor (with inverter) ❸	Engine Compartment	3-phase high voltage AC electrically driven motor compressor.
DC-DC Converter ❹ for 12 Volt Auxiliary Battery	Engine Compartment	Converts 288 Volts from the HV battery pack to 12 Volts for low voltage vehicle power.
DC-DC Converter ❺ for EPS	On HV Battery Pack	Converts 288 Volts from the HV battery pack to 46 Volts for EPS. Dull yellow colored sheathing identifies 46 Volts wires that are routed under the vehicle body to power the EPS.
Fuel Tank and Fuel Line ❶	Undercarriage, Left Side and Center	The fuel tank provides gasoline via a fuel line to the engine. The fuel line is routed along the left side and center tunnel under the floor pan.

*Numbers in the component column apply to the illustrations on the following page.

Hybrid Component Locations & Descriptions (Continued)

Specifications

Gasoline Engine:	292 ps (215 kW), 3.5-liter Aluminum Alloy Engine
Electric Motors	200 ps (147 kW), Permanent Magnet Motor
Transmission:	Automatic Only
HV Battery:	288 Volt Sealed NiMH-Battery
Curb Weight:	4,012-4,211 lbs/1,820-1,910 kg
Fuel Tank:	17.4 gals/66.0 liters
Frame Material:	Steel Unibody
Body Material:	Steel Panels except for Aluminum Engine Hood
Seating Capacity:	5 passenger

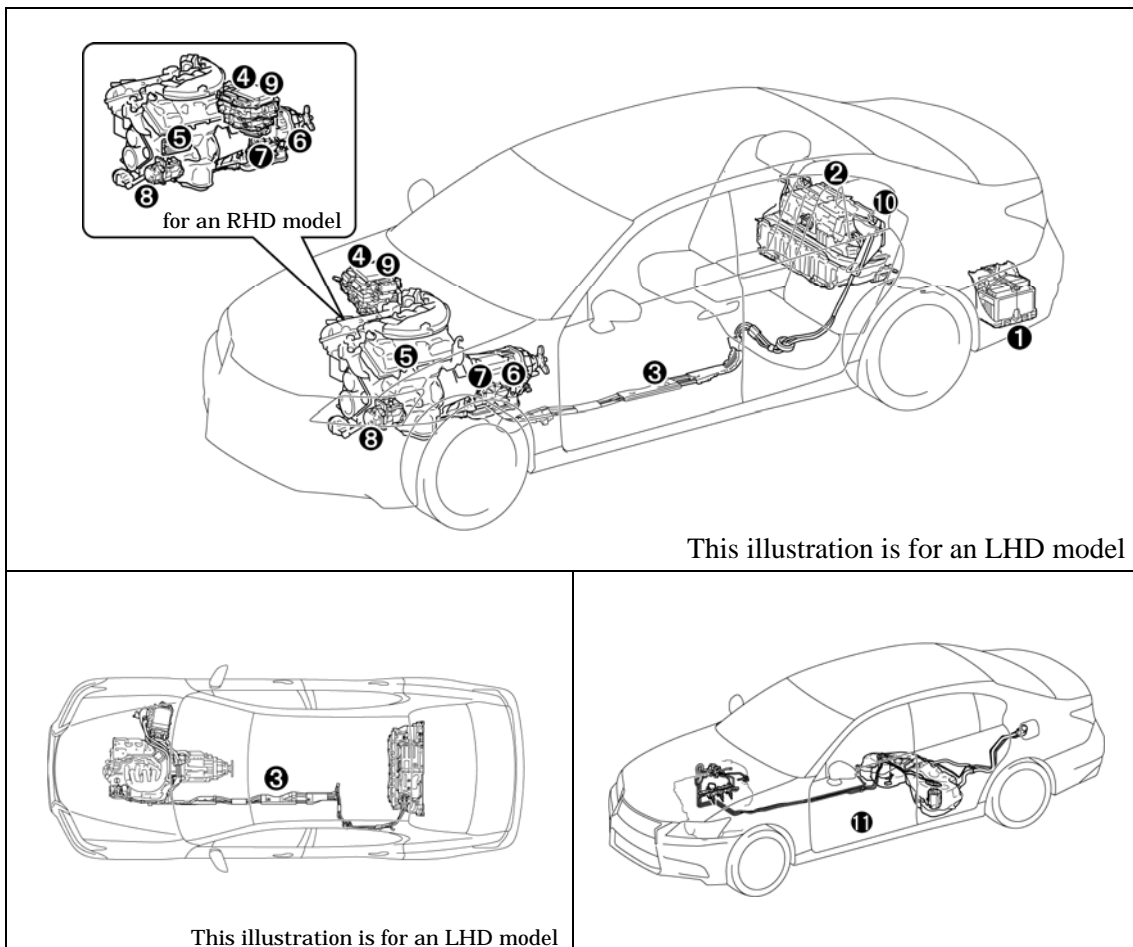

Hybrid Component Locations & Descriptions (Continued)

Lexus Hybrid Drive Operation

Once the **READY** indicator is illuminated in the instrument cluster, the vehicle may be driven. However, the gasoline engine does not idle like a typical automobile and will start and stop automatically. It is important to recognize and understand the **READY** indicator provided in the instrument cluster. When illuminated, it informs the driver that the vehicle is on and operational even though the gasoline engine may be off and the engine compartment is silent.

Vehicle Operation

- With the GS450h, the gasoline engine may stop and start at any time while the **READY** indicator is on.
- Never assume that the vehicle is shut off just because the engine is off. Always look for the **READY** indicator status. The vehicle is shut off when the **READY** indicator is off.

The vehicle may be powered by:

1. The electric motor only.
2. The gasoline engine only.
3. A combination of both the electric motor and the gasoline engine.

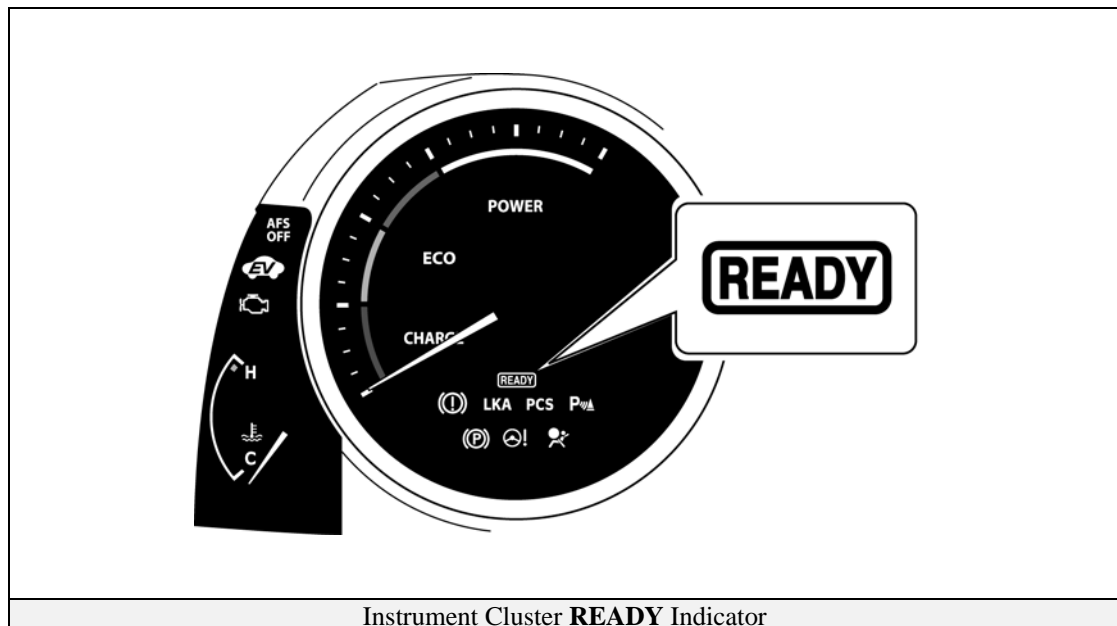

Hybrid Vehicle (HV) Battery Pack and Auxiliary Battery

The GS450h features a high voltage Hybrid Vehicle (HV) battery pack that contains sealed Nickel Metal Hydride (NiMH) battery modules.

HV Battery Pack

- The HV battery pack is enclosed in a metal case and is rigidly mounted to the trunk area behind the rear seat. The metal case is isolated from high voltage and concealed by fabric covers in the trunk.
- The HV battery pack consists of 40 low voltage (7.2 Volt) NiMH battery modules connected in series to produce approximately 288 Volts. Each NiMH battery module is non-spillable and sealed in a metal case.
- The electrolyte used in the NiMH battery module is an alkaline mixture of potassium and sodium hydroxide. The electrolyte is absorbed into the battery cell plates and will not normally leak, even in a collision.

HV Battery Pack	
Battery pack voltage	288 V
Number of NiMH battery modules in the pack	40
NiMH battery module voltage	7.2 V
NiMH battery module dimensions	10.9 x 0.8 x 4.2 in (276 x 20 x 106 mm)
NiMH module weight	2.3 lbs (1.0 kg)
NiMH battery pack dimensions	37 x 14.5 x 15.3 in (940 x 370 x 390 mm)
NiMH battery pack weight	140 lbs (63 kg)

Components Powered by the HV Battery Pack

- Electric Motor
- Power Cables
- Electric Generator
- DC-DC Converter for 12 Volt Auxiliary Battery
- Inverter/Converter
- A/C Compressor
- DC-DC Converter for EPS

Hybrid Vehicle (HV) Battery Pack and Auxiliary Battery (Continued)

HV Battery Pack Recycling

- The HV battery pack is recyclable. Contact either your Lexus Distributor as mentioned on HV battery Caution Label (see page 29) or the nearest Lexus dealer.

Auxiliary Battery

- The GS450h contains a sealed lead-acid 12 Volt battery. This 12 Volt auxiliary battery powers the vehicle electrical system similar to a conventional vehicle. As with other conventional vehicles, the negative terminal of the auxiliary battery is grounded to the metal chassis of the vehicle.
- The auxiliary battery is located in the trunk area. It is concealed by a fabric cover on the left side in the rear quarter panel well.

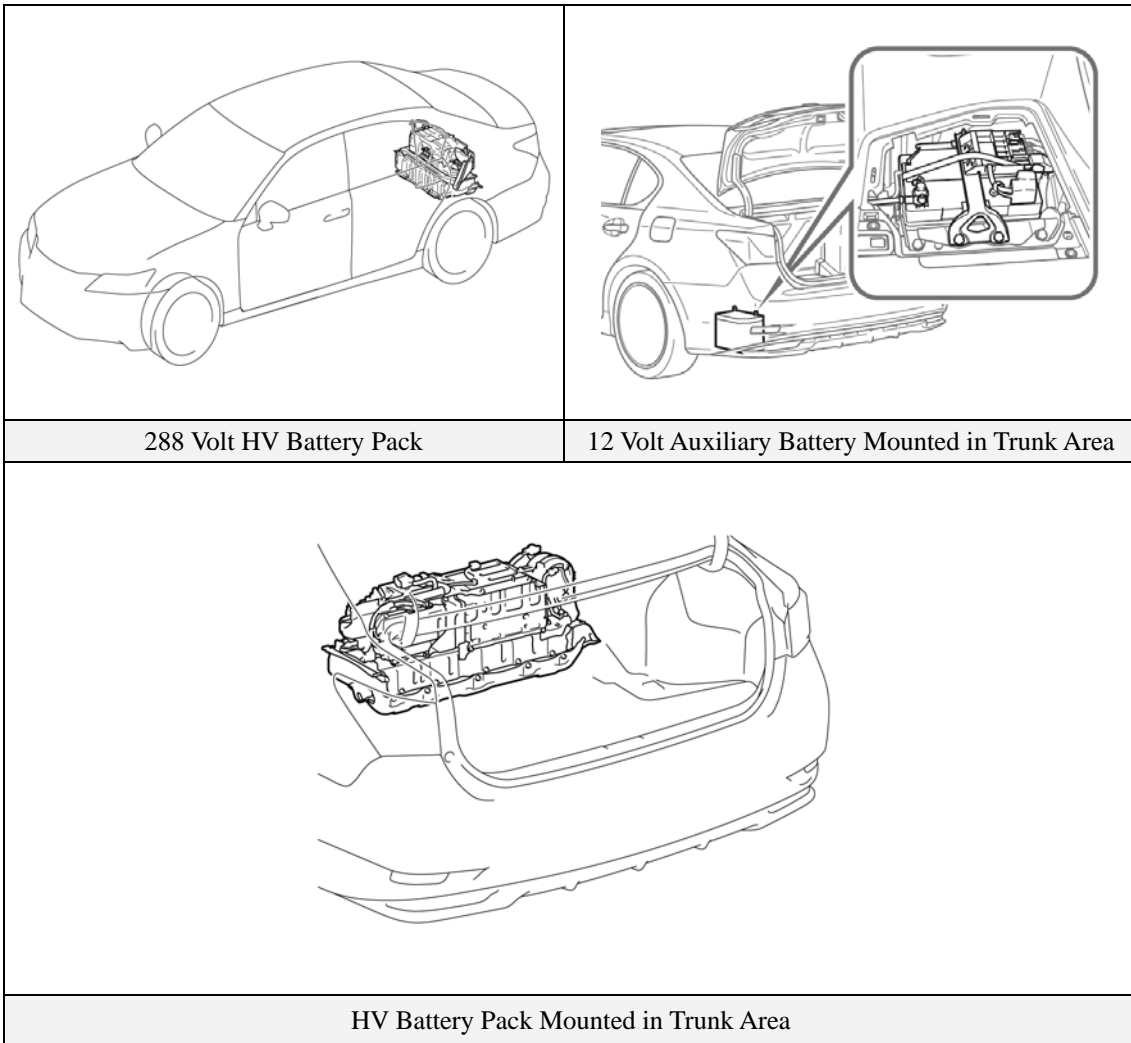

High Voltage Safety

The HV battery pack powers the high voltage electrical system with DC electricity. Positive and negative orange colored high voltage power cables are routed from the battery pack, under the vehicle floor pan, routed along the propeller shaft and transmission tunnel to the inverter/converter. The inverter/converter contains a circuit that boosts the HV battery voltage from 288 to 650 Volts DC. The inverter/converter creates 3-phase AC to power the motor. Power cables are routed from the inverter/converter to each high voltage motor (electric motor, electric generator, and A/C compressor). The following systems are intended to help keep occupants in the vehicle and emergency responders safe from high voltage electricity:

High Voltage Safety System

- A high voltage fuse ❶* provides short circuit protection in the HV battery pack.
- Positive and negative high voltage power cables ❷* connected to the HV battery pack are controlled by 12 Volt normally open relays ❸*. When the vehicle is shut off, the relays stop electricity flow from leaving the HV battery pack.



WARNING:

- ***The high voltage system may remain powered for up to 10 minutes after the vehicle is shut off or disabled. To prevent serious injury or death from severe burns or electric shock, avoid touching, cutting, or opening any orange high voltage power cable or high voltage component.***

- Both positive and negative power cables ❷* are insulated from the metal chassis, so there is no possibility of electric shock when touching the metal chassis.
- A ground-fault monitor ❹* continuously monitors for high voltage leakage to the metal chassis while the vehicle is running. If a malfunction is detected, the hybrid vehicle computer ❹* will illuminate the master warning light  in the instrument cluster and indicate “CHECK HYBRID SYSTEM” on the multi-information display.
- The HV battery pack relays will automatically open to stop electricity flow in a collision sufficient to activate the SRS.

*Numbers apply to the illustration on the following page.

High Voltage Safety (Continued)

Service Plug Grip

- The high voltage circuit is cut by removing the service plug grip (see page 15).

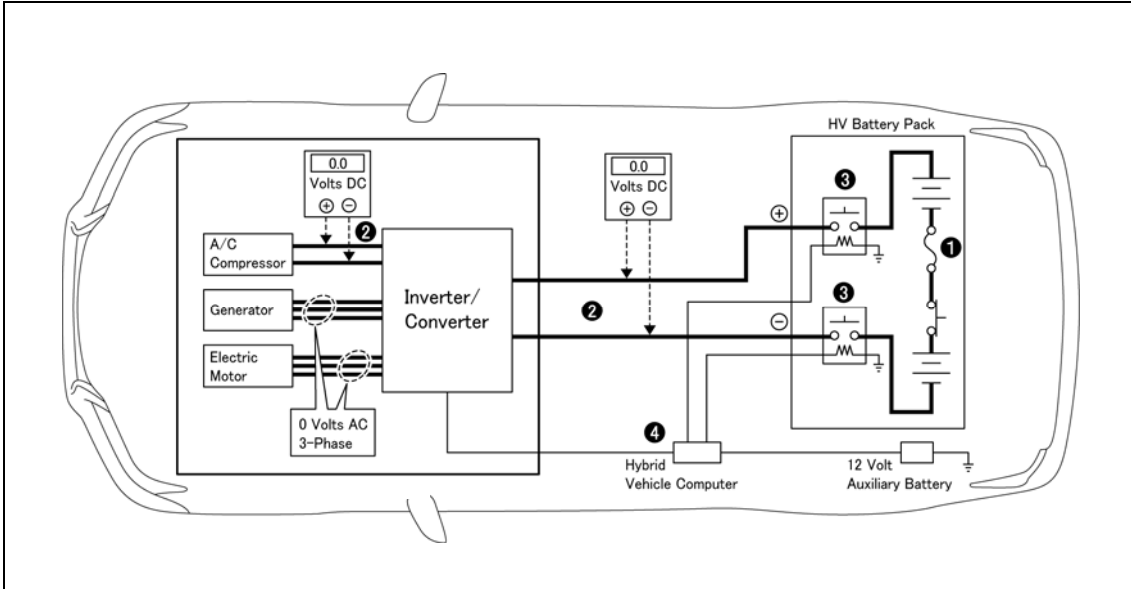

High Voltage Safety System – Vehicle Shut Off (**READY-OFF**)

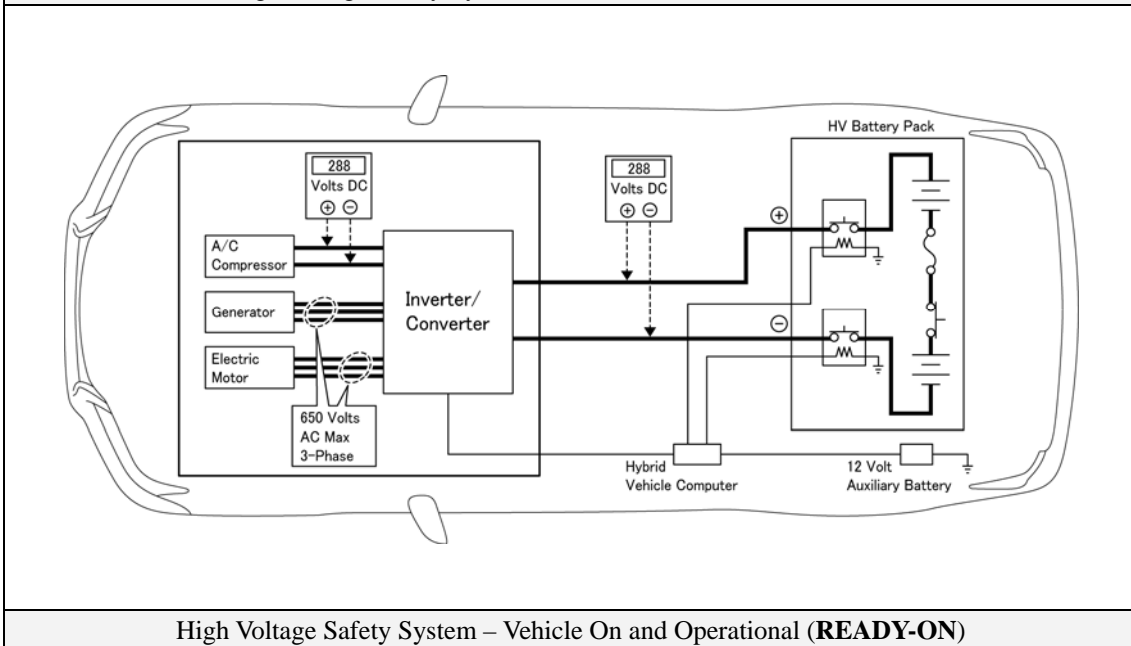

High Voltage Safety System – Vehicle On and Operational (**READY-ON**)

Precaution to be observed when dismantling the vehicle



WARNING:

- *The high voltage system may remain powered for up to 10 minutes after the vehicle is shut off or disabled. To prevent serious injury or death from severe burns or electric shock, avoid touching, cutting, or opening any orange high voltage power cable or high voltage component.*

Necessary Items

- Protective clothing such as insulated gloves (electrically insulated), rubber gloves, safety goggles, and safety shoes.
- Insulating tape such as electrical tape that has a suitable electrical insulation rating.
- Before wearing insulated gloves, make sure that they are not cracked, ruptured, torn, or damaged in any way. Do not wear wet insulated gloves.
- An electrical tester that is capable of measuring DC 750 Volts or more.

Spills

The GS450h contains the same common automotive fluids used in other non-hybrid Lexus vehicles, with the exception of the NiMH electrolyte used in the HV battery pack. The NiMH battery electrolyte is a caustic alkaline (pH 13.5) that is damaging to human tissues. The electrolyte, however, is absorbed in the cell plates and will not normally spill or leak out even if a metal battery module is cracked. A catastrophic crash that would breach both the metal battery pack case and a metal battery module would be a rare occurrence.

A caustic alkaline is at the opposite end of the pH scale from a strong acid. A safe (neutral) substance is approximately in the middle of this scale. Adding a weak acidic mixture, such as a dilute boric acid solution or vinegar, to the caustic alkaline electrolyte will cause the electrolyte to be neutralized. This is similar but opposite to the use of baking soda to neutralize a lead-acid battery electrolyte spill.

A Lexus Product Safety Data Sheets (PSDS) is attached to this document.

- Handle NiMH electrolyte spills using the following Personal Protective Equipment (PPE):
 - Splash shield or safety goggles. A fold down face shield is not acceptable for acid or electrolyte spills.
 - Rubber, latex or nitrile gloves.
 - Apron suitable for alkaline.
 - Rubber boots.

- Neutralize NiMH electrolyte.
 - Use a boric acid solution or vinegar.
 - Boric acid solution - 800 grams boric acid to 20 liters water or 5.5 ounces boric acid to 1 gallon of water.

Dismantling the vehicle

The following 2 pages contain general instructions for use when working on a GS450h.

Read these instructions before proceeding to the HV battery removal instructions on page 18.



WARNING:

- ***The high voltage system may remain powered for up to 10 minutes after the vehicle is shut off or disabled. To prevent serious injury or death from severe burns or electric shock, avoid touching, cutting, or opening any orange high voltage power cable or any high voltage component.***

1. Shut off the ignition (**READY** indicator is off).

Then disconnect the cable from the auxiliary battery negative (-) terminal.

- (1) Remove the luggage compartment floor mat.
- (2) Remove the luggage compartment side trim cover LH.
- (3) Disconnect the battery negative terminal.

2. Remove the service plug grip.

- (1) Remove the No. 1 seat armrest cap.
- (2) Remove the 4 nuts and lower hybrid vehicle battery cover panel.

Caution:

Wear insulated gloves for the following 3 steps.

- (3) Slide the handle of the service plug grip to the right.
- (4) Raise the service plug grip.
- (5) Remove the service plug grip
- (6) Apply insulating tape to the socket of the service plug grip to insulate it.

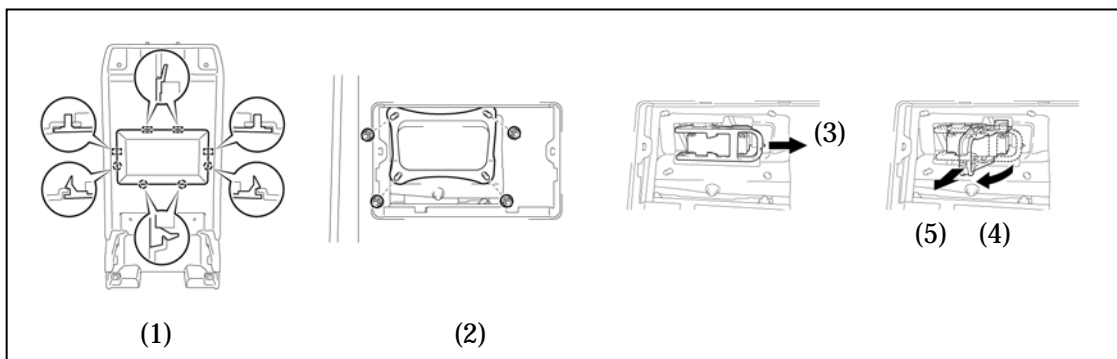

3. Carry the removed service plug grip in your pocket to prevent other staff from accidentally reinstalling it while you are dismantling the vehicle.
4. Make other staff aware that a high-voltage system is being dismantled by using the following sign: CAUTION: HIGH-VOLTAGE. DO NOT TOUCH (see page 17).
5. If the service plug grip cannot be removed due to damage to the vehicle, remove the **IG2 MAIN** fuse (20 A).

Caution:

This operation shuts off the HV system. Be sure to wear insulated gloves because high voltage is not shut off inside the HV battery. When it is possible to remove the service plug grip, remove it and continue the procedure.

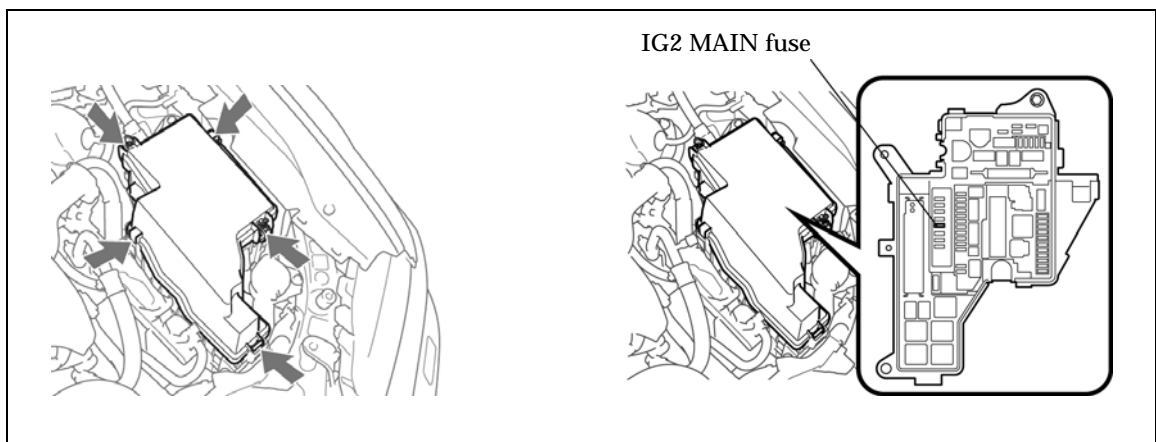

6. After disconnecting or exposing a high-voltage connector or terminal, insulate it immediately using insulating tape. Before disconnecting or touching a bare high-voltage terminal, wear insulated gloves.

7. Check the HV battery and nearby area for leakage. If you find any liquid, it may be strong alkaline electrolyte. Wear rubber gloves and goggles and neutralize the liquid using a saturated boric acid solution or vinegar. Then wipe up the liquid using waste rags etc.

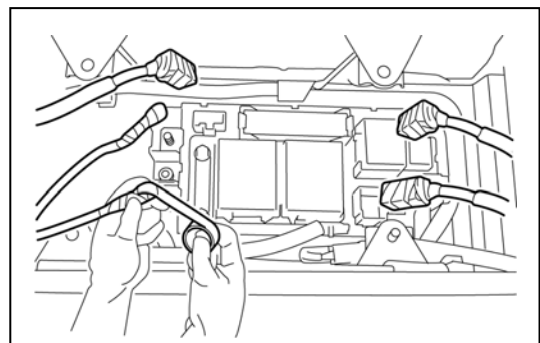

8. If the electrolyte comes into contact with your skin, wash the skin immediately using a saturated boric acid solution or a large amount of water. If the electrolyte adheres to any article of clothing, take the clothing off immediately.

9. If the electrolyte comes into contact with your eye(s), call out loudly for help. Do not rub your eye(s). Instead, wash the eye(s) with a dilute boric acid solution or a large amount of water and seek medical care.

10. With the exception of the HV battery, remove parts by following procedures which are similar to conventional Lexus vehicles. For the removal of the HV battery, refer to the following pages.

Person in charge: _____

CAUTION:
HIGH-VOLTAGE.
DO NOT TOUCH.

CAUTION:
HIGH-VOLTAGE.
DO NOT TOUCH.

Person in charge: _____

When performing work on the HV system, fold this sign and
put it on the roof of the vehicle.

Removal of HV battery



WARNING:

- *Be sure to wear insulated gloves when handling high-voltage parts.*
- *Even if the vehicle is shut off and the relays are off, be sure to remove the service plug grip before performing any further work.*
- *Power remains in the high voltage electrical system for 10 minutes even after the HV battery pack is shut off because the circuit has a condenser that stores power.*
- *Make sure that the tester reading is 0 V before touching any high-voltage terminals which are not insulated.*
- *The SRS may remain powered for up to 90 seconds after the vehicle is shut off or disabled. To prevent serious injury or death from unintentional SRS deployment, avoid cutting the SRS components.*

1. SHUT OFF IGINATION (**READY** indicator is off).
2. REMOVE LUGGAGE COMPARTMENT FLOOR MAT.
3. REMOVE 12 VOLT AUXILIARY BATTERY
 - (1) Remove the luggage compartment trim cover LH.
 - (2) Disconnect the cable from the auxiliary battery negative (-) terminal.
 - (3) Disconnect the cable from the auxiliary battery positive (+) terminal.
 - (4) Remove the 12 Volt auxiliary battery.

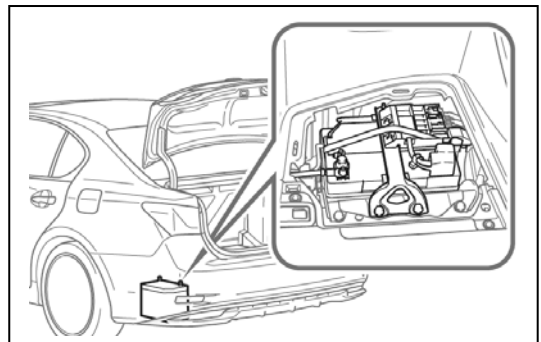
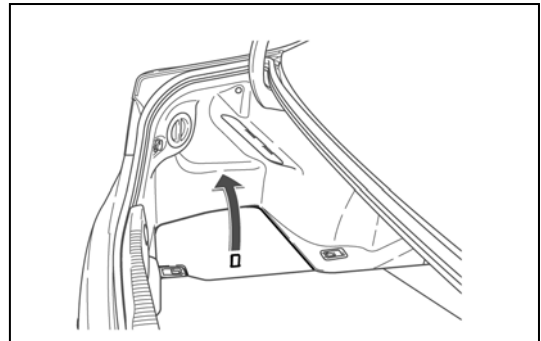

4. REMOVE SERVICE PLUG GRIP

- (1) Remove the No. 1 seat armrest cap.
- (2) Remove the 4 nuts and lower hybrid vehicle battery cover panel.

Caution:

Wear insulated gloves for the following 3 steps.

- (3) Slide the handle of the service plug grip to the right.
- (4) Raise the service plug grip.
- (5) Remove the service plug grip.
- (6) Apply insulating tape to the socket of the service plug grip to insulate it.

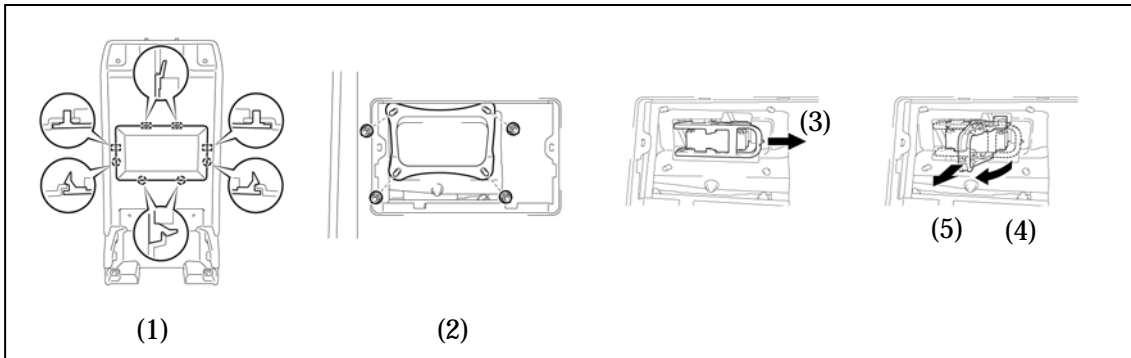

5. REMOVE INVERTER COVER

Disengage the 3 clip, and remove the inverter cover.

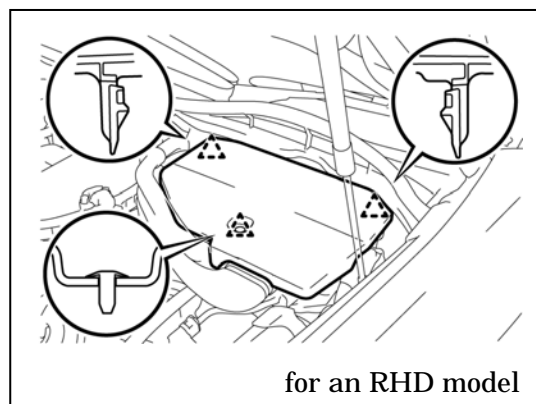
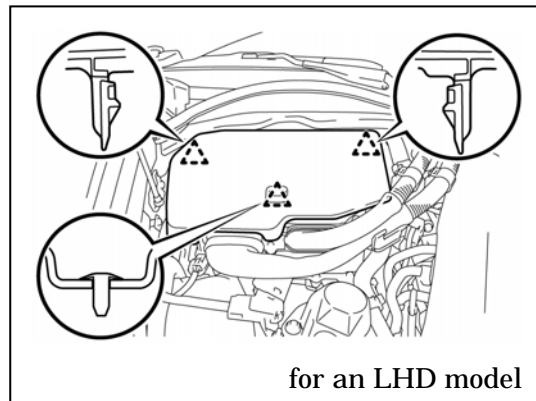

6. REMOVE CONNERCTOR COVER ASSEMBLY

Remove the 2 bolts and connector cover assembly.

Caution:

Wear insulated gloves.

Notice:

Do not touch the high voltage connectors or terminals for 10 minutes after the service plug grip is removed.

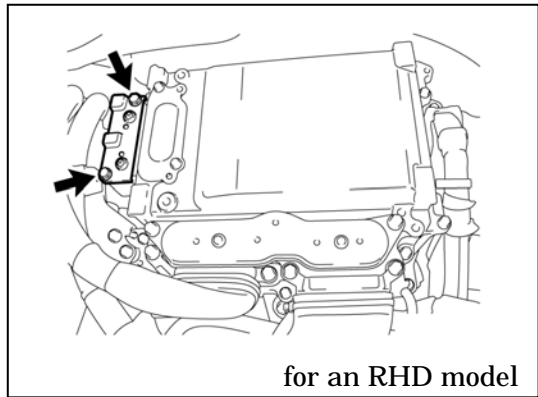
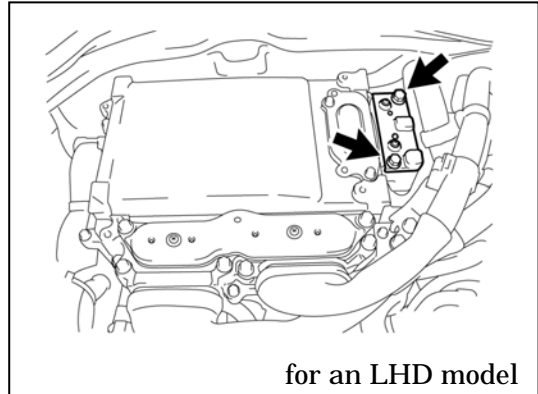

7. CHECK TERMINAL VOLTAGE

Check the voltage at the terminals in inspection point in the power control unit.

Caution:

Wear insulated gloves.

To prevent serious injury or death, do not proceed with dismantling of the HV system until the voltage at the terminals in the inspection point is 0 V.

Standard voltage: 0 V

Hint:

Set the tester to the DC 750 Volts range to measure the voltage.

This inspection is performed to verify that it is safe to remove the HV battery.

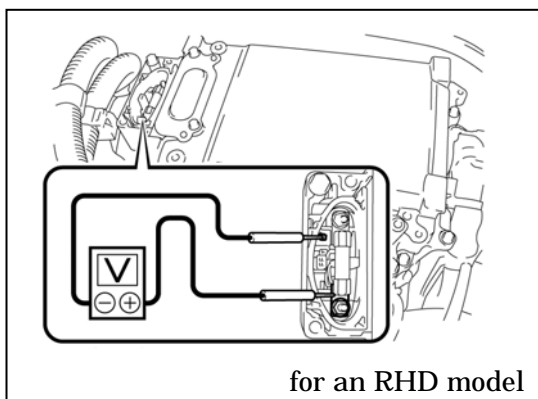
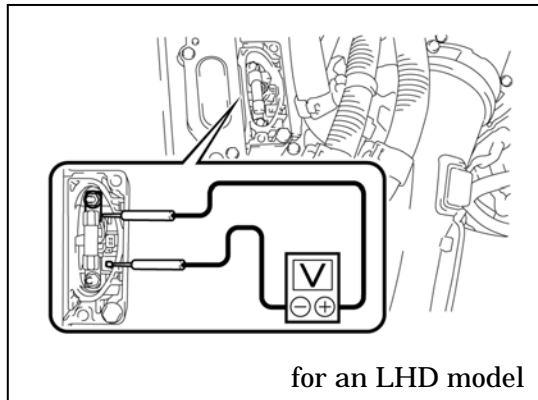

8. REMOVE REAR SEAT ASSEMBLY

- (1) Remove the rear seat cushion assembly.
- (2) Cut the seat belts CTR, LH, and RH.
- (3) Remove the rear seatback assembly.

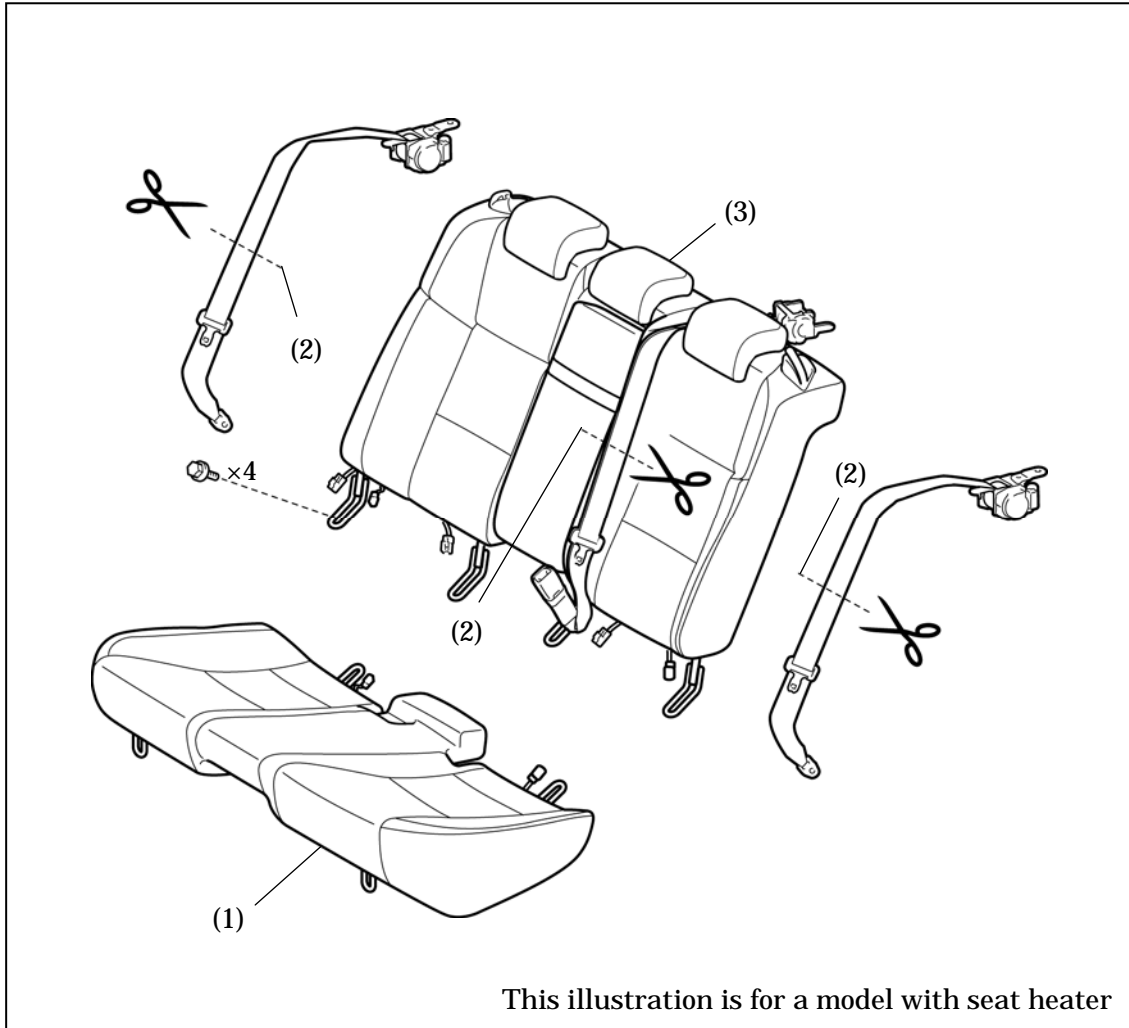

Caution:

Do not cut wiring or wire harnesses when removing vehicle components.

Always disconnect components at the connector.

9. REMOVE NO. 1 ROOM PARTITION PAD

- (1) Remove the rear door scuff plate LH and RH.
- (2) Remove the rear seat side garnish LH and RH.
- (3) Remove the inner roof side garnish LH and RH.
- (4) Remove the center stop light cover. (without rear sunshade system)
- (5) Remove the package tray trim panel assembly.
- (6) Remove the No. 1 room partition pad.

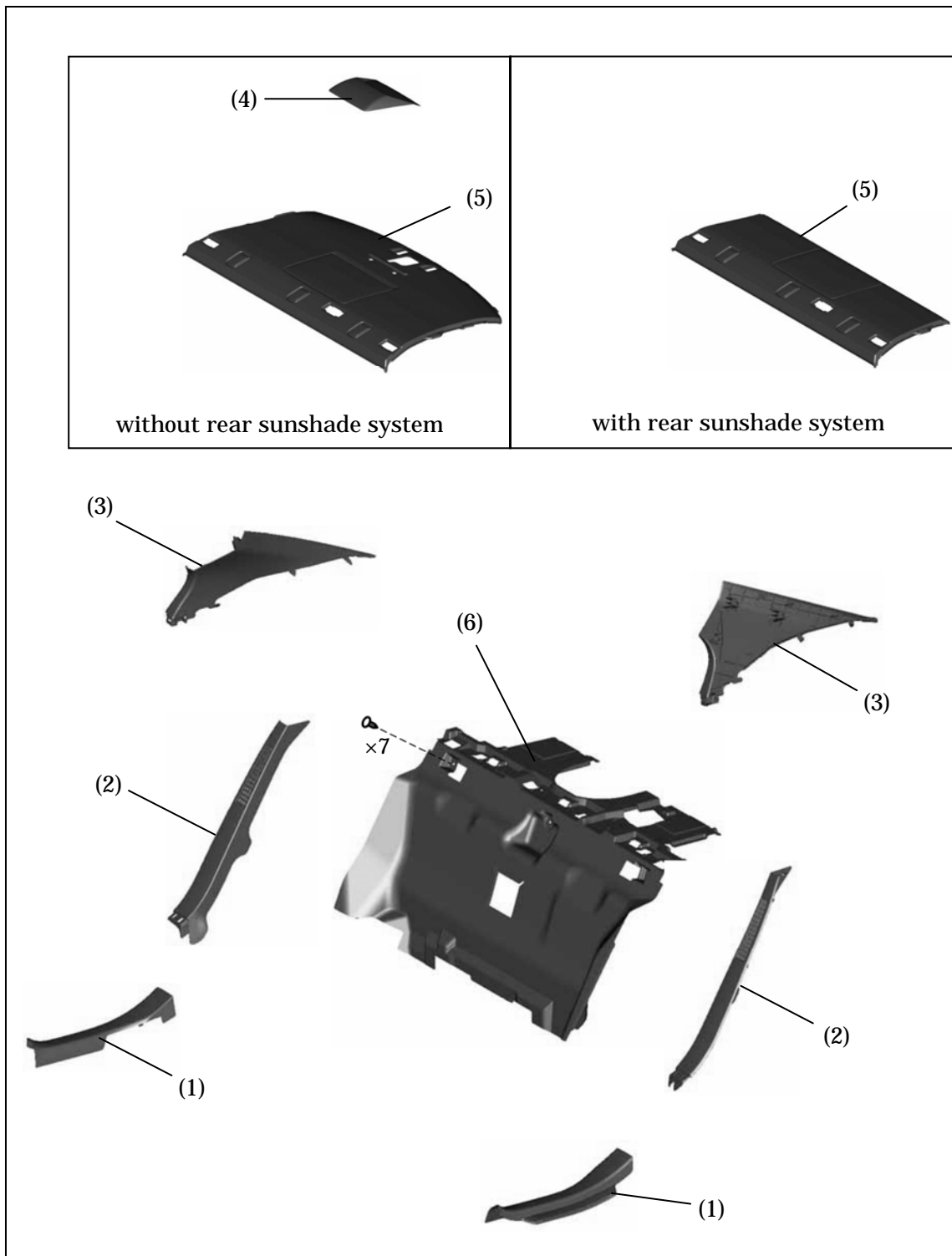

10. REMOVE FRONT LUGGAGE COMPARTMENT TRIM COVER

- (1) Remove the luggage compartment trim cover RH.
- (2) Remove the side trim box.
- (3) Remove the luggage compartment side tray. (with spare tire model)
- (4) Remove the rope hook assembly.
- (5) Remove the rear luggage compartment tray bracket LH and RH.
- (6) Remove the No. 1 luggage compartment trim hook.
- (7) Remove the No. 1 luggage compartment light assembly.
- (8) Remove the rear luggage compartment trim cover

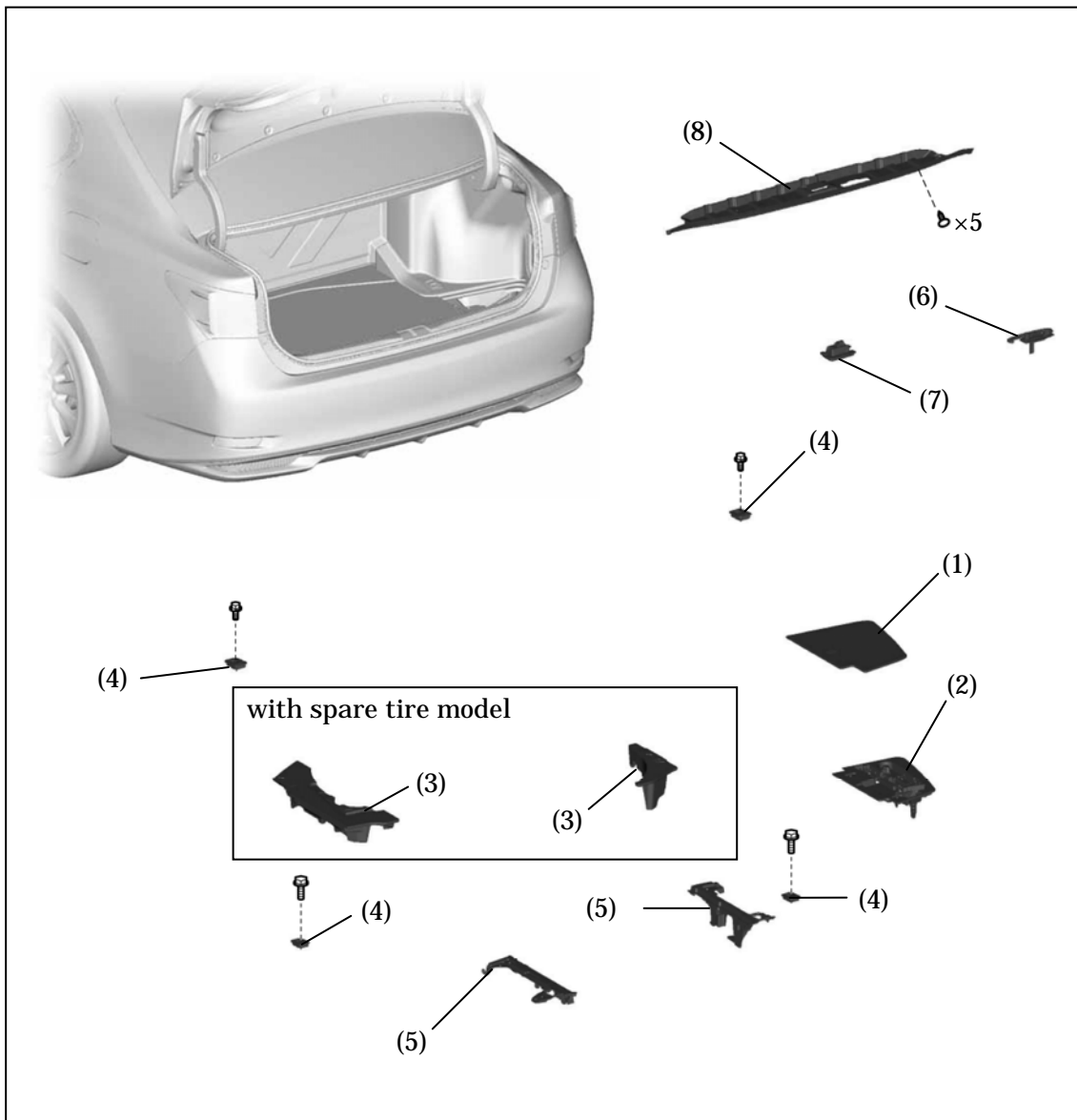

11. REMOVE LUGGAGE COMPARTMENT TRIM INNER COVER

- (1) Remove the rear floor finish plate.
- (2) Remove the front luggage compartment trim cover.
- (3) Remove the rope hook.
- (4) Remove the inner luggage compartment trim cover LH and RH.

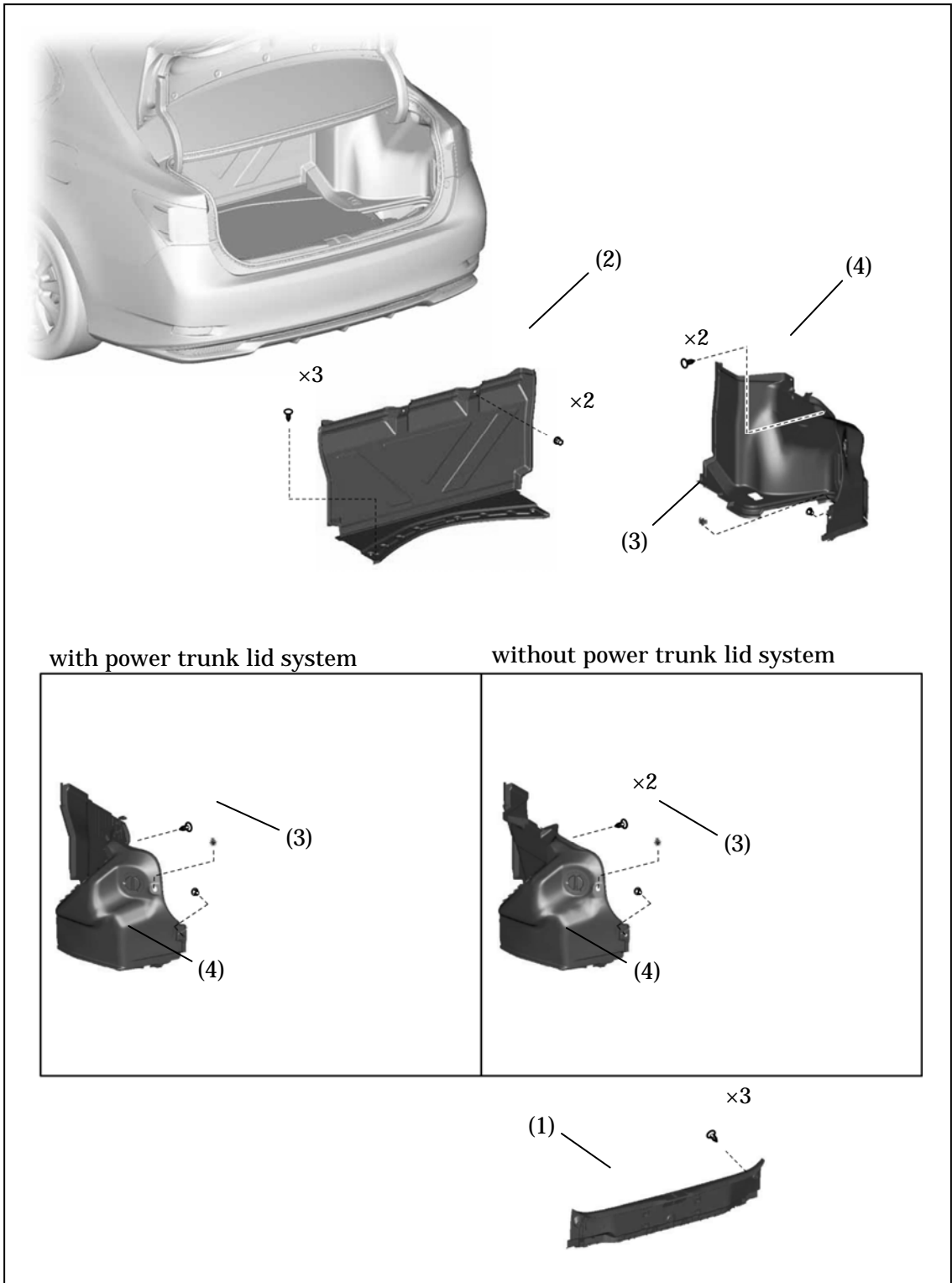

12. REMOVE NO. 4 HYBRID VEHICLE BATTERY SHIELD SUB-ASSEMBLY

Caution:

Wear insulated gloves.

- (1) Using the service plug grip, release the battery cover lock striker.
- (2) Remove the 4 nuts and No. 4 hybrid vehicle battery shield sub-assembly.

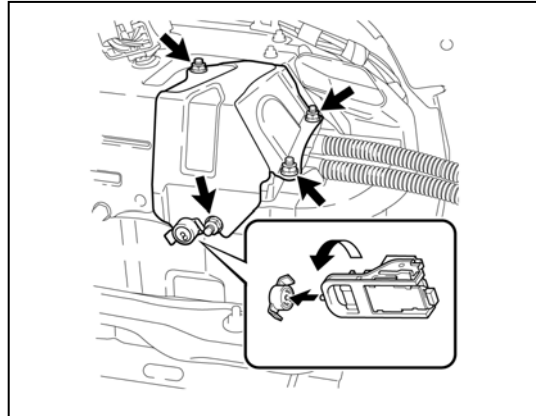

13. DISCONNECT NO. 4 FLOOR WIRE

Caution:

Wear insulated gloves.

- (1) Remove the battery shield contact.

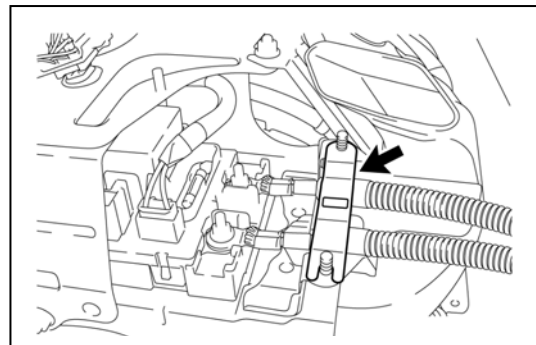

- (2) Remove the 2 nuts and disconnect the 2 wires of the No. 4 floor wire. (High voltage cable)

Notice:

Insulate the terminals of the removed frame wire with insulating tape.

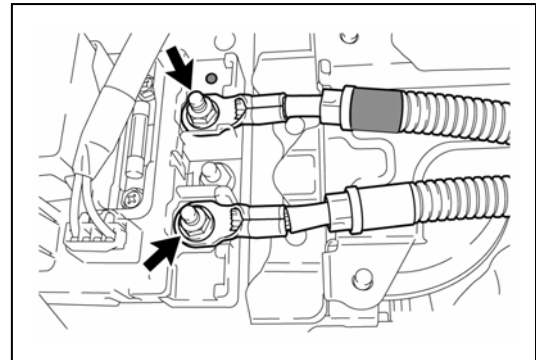

14. REMOVE No. 1 HYBRID BATTERY INTAKE DUCT LH

Remove the 2 clips and No. 1 hybrid battery intake duct LH.

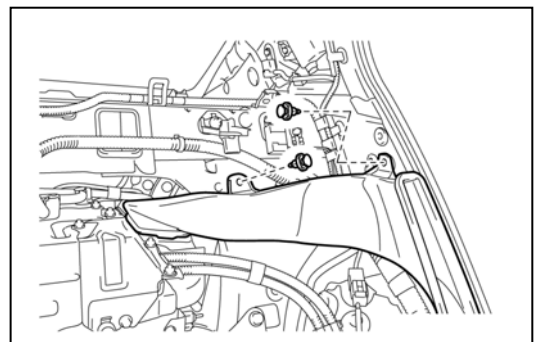

15. REMOVE NO. 1 HYBRID BATTERY
INTAKE DUCT RH

Remove the 2 clips and No. 1 hybrid battery
intake duct RH.

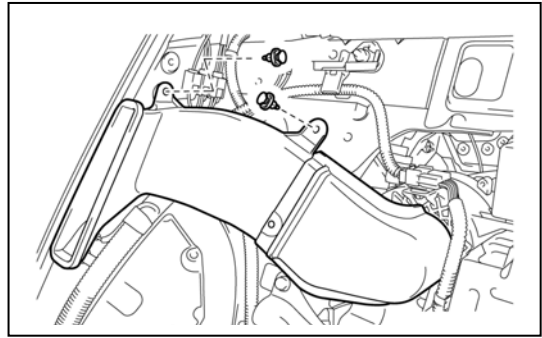

16. REMOVE BRAKE CONTROL POWER
SUPPLY ASSEMBLY

Remove the 2 bolts and brake control power
supply assembly.

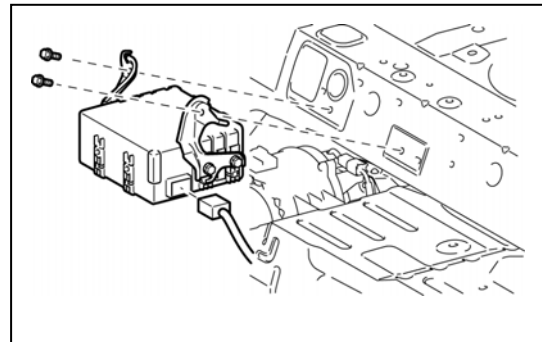

17. REMOVE NO. 1 HYBRID BATTERY
CARRIER BRACKET

Caution:

Wear insulated gloves.

- (1) Remove the 2 nuts.
- (2) Remove the 4 bolts and No. 1 hybrid
battery carrier bracket.

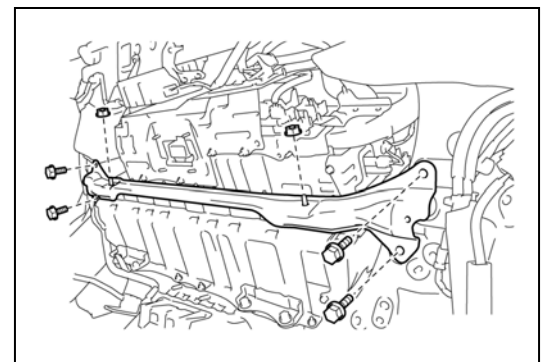

18. REMOVE HYBRID VEHICLE BATTERY

Caution:

Wear insulated gloves.

- (1) Disconnect the connector from the battery
cooling blower assembly.

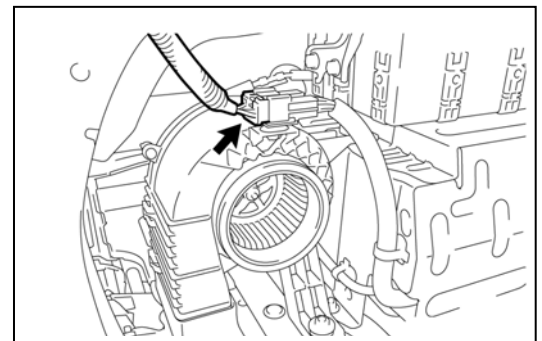

(2) Disconnect the 2 connectors.

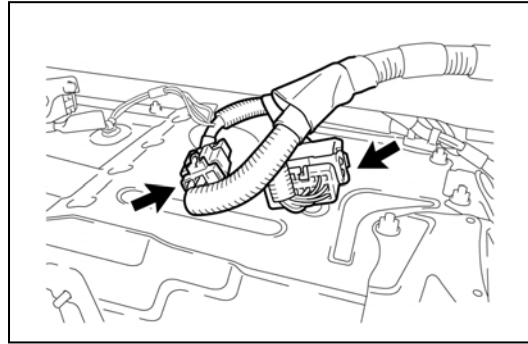

(3) Remove the 4 bolts.

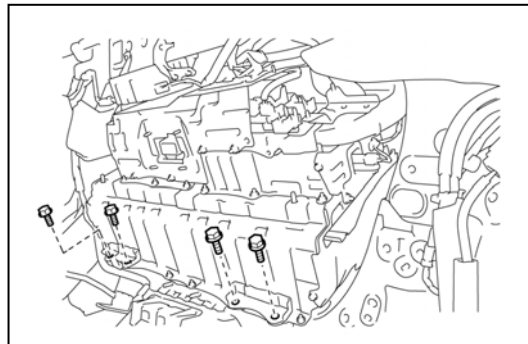

(4) Remove the 2 nuts.

(5) Install the luggage compartment floor mat upside down.

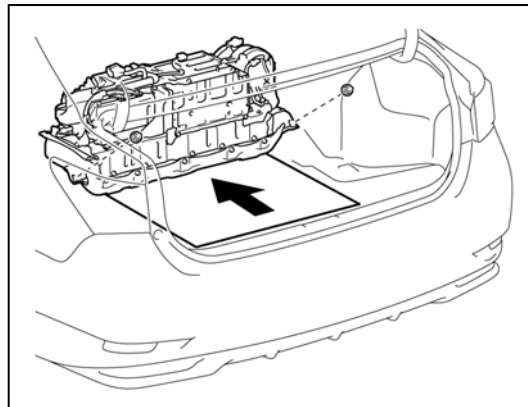

(6) Pull out the HV battery onto the luggage compartment floor mat.

Notice:

When pulling out the HV battery, 2 people are needed. One should work from the luggage compartment side and the other from the cabin side.

When pulling out the HV battery, do not allow the wire harnesses and the HV battery case to interfere with the vehicle body.

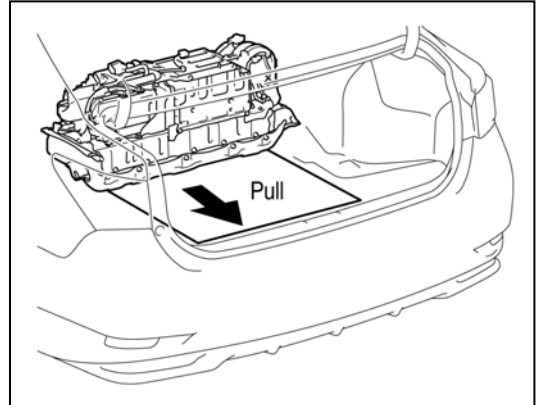

(7) Using a suitable adaptor such as a rope, remove the HV battery while tilting the HV battery.

Notice:

Use cardboard or other similar material to protect the HV battery and vehicle body from damage.

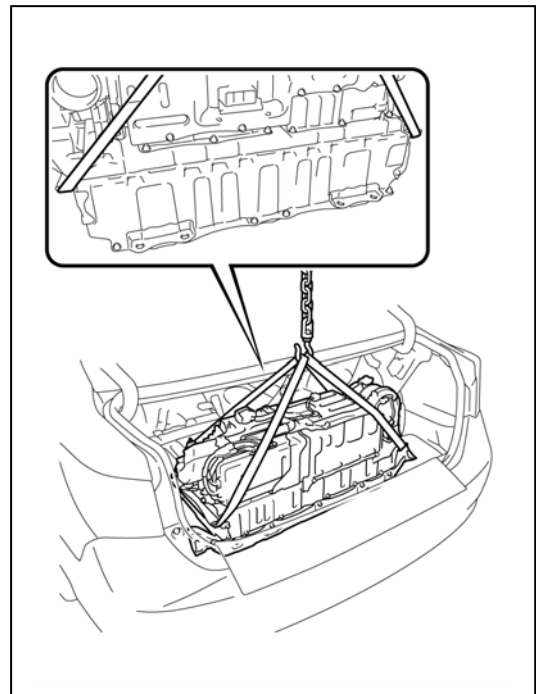

19. The HV battery pack is recyclable. Contact your Lexus distributor (if included on the HV battery caution label) or contact the nearest Lexus dealer (see the next 2 pages for samples of the HV battery caution label).

Caution:

After removing the HV battery, do not reinstall the service plug grip to the HV battery.

HV Battery Caution Label

1. For U.S.A.

DANGER High Voltage Inside/Alkaline Electrolyte Ni-MH	To the Qualified EV Technicians: Be sure to read the Repair Manual when servicing or replacing the battery. HV Battery Recycling Information ● Please transport this battery in accordance with all applicable laws. ● Be sure to consult your dealer or the following address for replacing and disposing of this battery.
	Residents in U.S.A. ◆ TOYOTA MOTOR SALES U.S.A. INC. TORRANCE, CAL. 90501 Phone: 1-800-331-4331 ◆ SERVCO PACIFIC INC. HONOLULU, HAWAII 96813 Phone: 808-839-2273
To avoid injuries, burns or electric shocks: ● Never disassemble this battery unit or remove its covers. — Service by Qualified Technician. — ● Avoid contact alkaline electrolyte with eyes, skin or clothes. In event of accident, flush with water and get medical help immediately. ● Keep children away from this unit. ● Do not puncture or impact on this unit when operating forklift, or expose to open flame or incinerate, or expose to liquids when stoning this unit, as excessive heat may generate fire and electrolyte may leak out.	Residents in PUERTO RICO ◆ TOYOTA DE PUERTO RICO HATO REY, PUERTO RICO Phone: 787-751-1000

2. For Canada

DANGER High Voltage Inside / Alkaline Electrolyte Ni-MH	To the Qualified EV Technicians: Be sure to read the Repair Manual when servicing or replacing the battery. HV Battery Recycling Information ● Please transport this battery in accordance with all applicable laws. ● Be sure to consult your dealer or the following address for replacing and disposing of this battery. TOYOTA CANADA INC. ONE TOYOTA PLACE SCARBOROUGH, ONTARIO M1H 1H6 Phone: 1-888-TOYOTA-6 (1-888-853-8286) URL: www.toyota.ca
	Haute tension à l'intérieur / Electrolyte alcalin Afin d'éviter des blessures et brûlures et tout choc électrique: ● Ne jamais démonter cet ensemble batterie ni enlever ses couvercles. — Confier l'entretien à un technicien qualifié. — ● Éviter tout contact de l'électrolyte alcalin avec les yeux, la peau ou les vêtements. En cas d'accident, rincer à l'eau et contacter un médecin immédiatement. ● Garder cet ensemble hors de portée des enfants. ● Ne pas percer cet ensemble et ne pas lui faire subir d'impact lors de l'utilisation du chariot élévateur. Ne pas l'exposer à une flamme vive ni l'incinérer. Ne pas l'exposer à un liquide lors du stockage. Une chaleur excessive pourrait provoquer un incendie et l'électrolyte pourrait fuir.
To avoid injuries, burns or electric shocks: ● Never disassemble this battery unit or remove its covers. — Service by Qualified Technician. — ● Avoid contact alkaline electrolyte with eyes, skin or clothes. In event of accident, flush with water and get medical help immediately. ● Keep children away from this unit. ● Do not puncture or impact on this unit when operating forklift, or expose to open flame or incinerate, or expose to liquids when stoning this unit, as excessive heat may generate fire and electrolyte may leak out.	A l'attention des techniciens spécialistes en véhicules électriques: Veiller à lire le manuel de réparation lors de l'entretien ou du remplacement de la batterie. Information sur le recyclage de batterie de véhicule hybride ● Prière de transporter cette batterie conformément à toutes les lois applicables. ● Pour le remplacement et la mise au rebut de cette batterie, veiller à consulter votre concessionnaire ou se renseigner à l'adresse suivante.

3. For Europe

DANGER High Voltage Inside / Alkaline Electrolyte Ni-MH	To the Qualified EV Technicians: Be sure to read the Repair Manual when servicing or replacing the battery. HV Battery Recycling Information ● Please transport this battery in accordance with all applicable laws. ● Be sure to consult your dealer or your national distributor as mentioned in your Dealer Guide-Book for replacing and disposing of this battery.
	Haute tension à l'intérieur / Electrolyte alcalin Afin d'éviter des blessures et brûlures et tout choc électrique: ● Ne jamais démonter cet ensemble batterie ni enlever ses couvercles. — Confier l'entretien à un technicien qualifié. — ● Éviter tout contact de l'électrolyte alcalin avec les yeux, la peau ou les vêtements. En cas d'accident, rincer à l'eau et contacter un médecin immédiatement. ● Garder cet ensemble hors de portée des enfants. ● Ne pas percer cet ensemble et ne pas lui faire subir d'impact lors de l'utilisation du chariot élévateur. Ne pas l'exposer à une flamme vive ni l'incinérer. Ne pas l'exposer à un liquide lors du stockage. Une chaleur excessive pourrait provoquer un incendie et l'électrolyte pourrait fuir.
To avoid injuries, burns or electric shocks: ● Never disassemble this battery unit or remove its covers. — Service by Qualified Technician. — ● Avoid contact alkaline electrolyte with eyes, skin or clothes. In event of accident, flush with water and get medical help immediately. ● Keep children away from this unit. ● Do not puncture or impact on this unit when operating forklift, or expose to open flame or incinerate, or expose to liquids when stoning this unit, as excessive heat may generate fire and electrolyte may leak out.	A l'attention des techniciens spécialistes en véhicules électriques: Veiller à lire le manuel de réparation lors de l'entretien ou du remplacement de la batterie. Information sur le recyclage de batterie de véhicule hybride ● Prière de transporter cette batterie conformément à toutes les lois applicables. ● Pour le remplacement et la disposition de cette batterie, se renseigner de consulter un votre concessionnaire ou distributeur national, comme mentionnées dans le guide des concessionnaires.

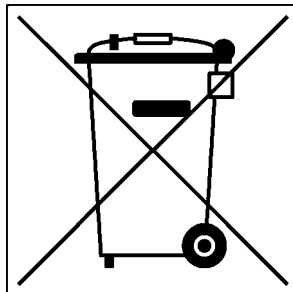

4. Russia

	Высокое напряжение/щелочной электролит ● избежание травм, ожогов и порезов электрическим током; ● никогда не разбирайте аккумуляторную батарею и не снимайте с нее крышку. - Осуществляйте обслуживание аккумуляторной батареи у специалиста надлежащей квалификации - ● избегайте попадания щелочного электролита в глаза, на кожу или на одежду. В случае попадания электролита следует промыть пораженный участок водой и немедленно обратиться за медицинской помощью. ● не подпускайте детей к аккумуляторной батарее. ● избегайте прокола аккумуляторной батареи или ударов по ней при работе с выключенным погрузчиком. ● не оставляйте аккумуляторную батарею вблизи открытого огня и не сжигайте ее. а также не подвергайте воздействию хлоридов во время хранения. Излишнее нагревание может вызвать пожар или утечку электролита.
	Информация для сертифицированных автоэлектриков: перед обслуживанием или заменой аккумуляторной батареи ознакомьтесь с руководством по ремонту. Информация об утилизации аккумуляторной батареи гибридного автомобиля ● Транспортировка аккумуляторной батареи должна осуществляться в соответствии со всеми применимыми законами. ● Относительно замены и способов утилизации аккумуляторной батареи проконсультируйтесь с дилером или дистрибьютором в вашей стране указанным в Руководстве по гарантийному обслуживанию.

